

Jennifer Newman | Ping-Pong

indoor/outdoor use

Simple, quick assembly

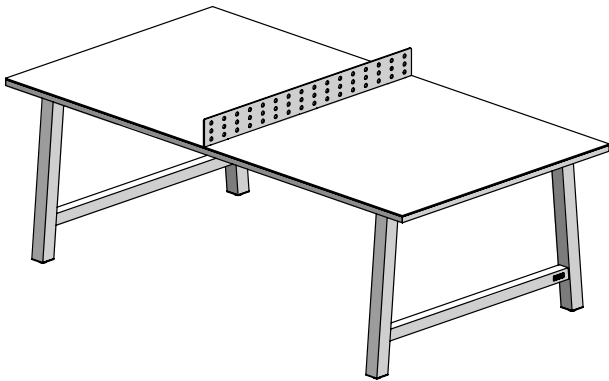

2300w x 1200d x 760h mm

Weight 80 kg

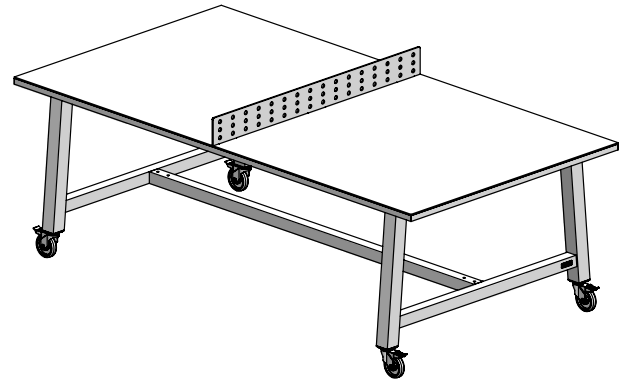

on castors
2300w x 1200d x 760h mm

Weight 85 kg

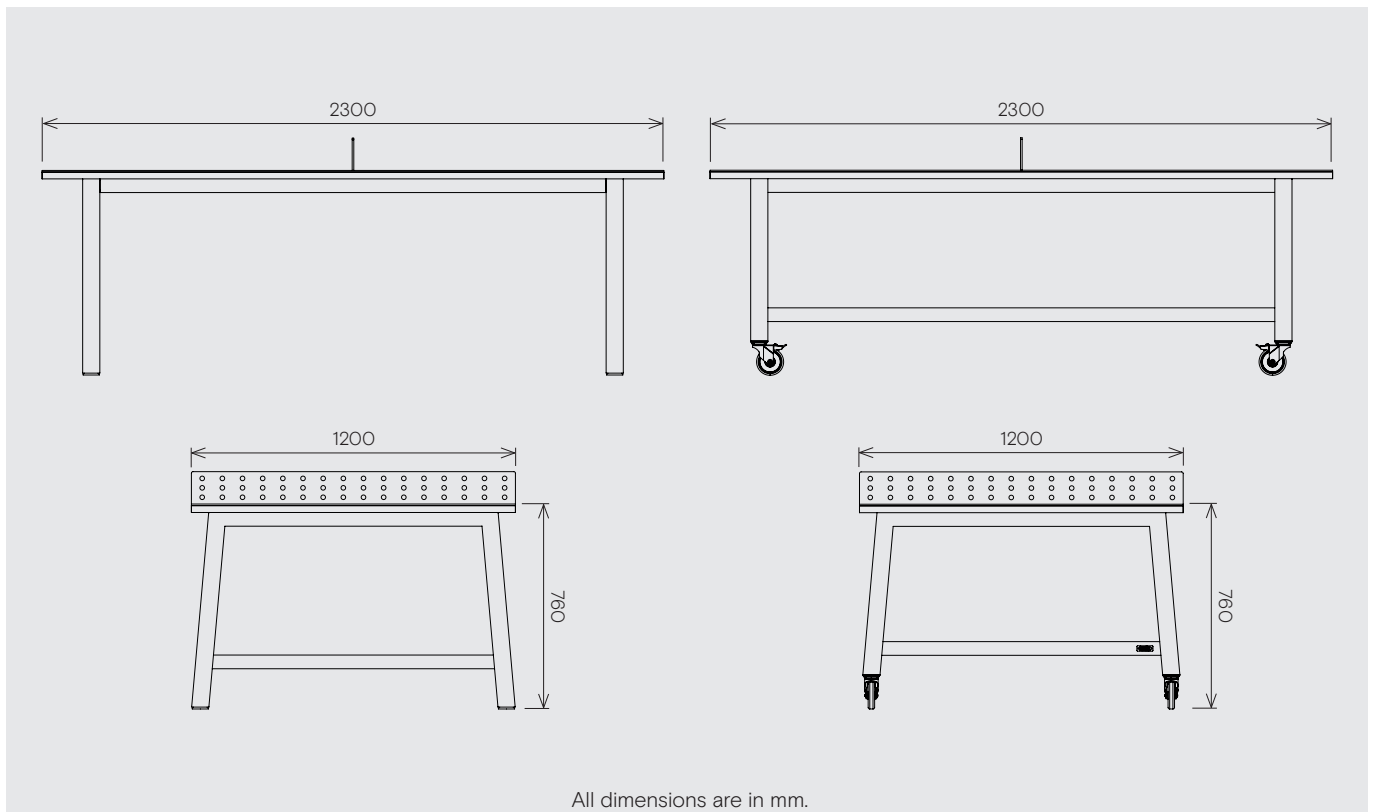

All dimensions are in mm.

Satin powder-coat finish providing:

- High resistance to wear-and-tear
- Long life durability
- Ease of cleaning
- Low maintenance
- Anti-bacterial and Volatile-Organic-Compound free.
- Exposed aluminium central stripe.

Other benefits and features:

- Aluminium for long-life, will not rust.
- Removable net.
- Stainless steel, heavy duty castor option.
- Withstands wind in exposed conditions.
- 12 standard colours, others on request (see separate reference sheet).