

# PING-PONG

Jennifer Newman

## Materials:

Polyester powder-coated aluminium.

## Optional Extras:

Non-standard colours.

Bolt-down brackets (fixings not supplied).

## Warranty:

5 years provided that products are cleaned and maintained in accordance with our advice and have not been misused.

## Assembly:

Assembly is required for this product. Instructions, diagrams and fixings are supplied. Please be careful when removing wrapping to avoid sharp implements damaging the surface.



## Dimensions & Weight

All dimensions in mm.

W	D	H	kg
2300	1200	760	80

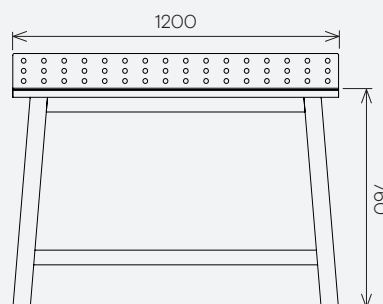
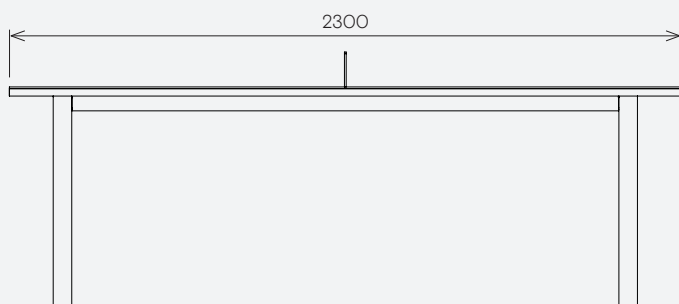

## Powder-coating standard colours

lacquer sealed



Sable  
BS 04-B-21



Oxide Red  
RAL 3009



Cream  
RAL 9001



Agate Grey  
RAL 7038



Light Blue  
BS 18-C-35



Black  
RAL 9004



Bronze



Gunmetal